



INTEGRATED REFINERY INFORMATION SYSTEM

ChevronTexaco – Pembroke Refinery

Presented for:
ERTC Computing Conference

June 10th – 12th, 2002

* * *

Barcelona, Spain



Agenda

- ◆ Pembroke Refinery overview
- ◆ Automation vision/investments
- ◆ IT benchmark and roadmap
- ◆ IRIS concept and scope
- ◆ Business improvement strategy
- ◆ Integration philosophy
- ◆ IRIS architecture
- ◆ Project schedule and resources
- ◆ IRIS business case
- ◆ Issues and lessons learned



Pembroke Plant Overview

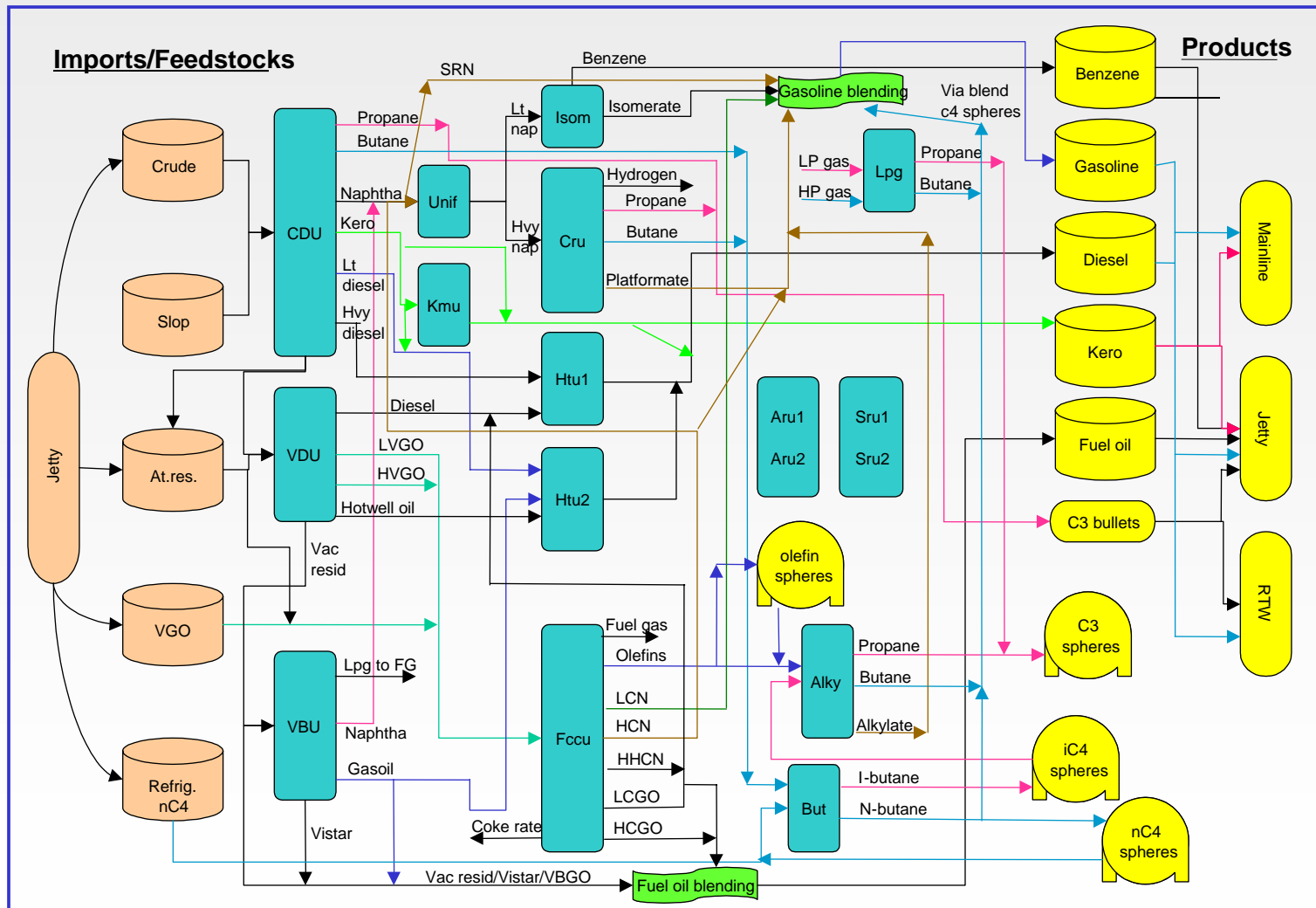

Throughput: 13 Million tonnes per year



Refinery Wide Optimization

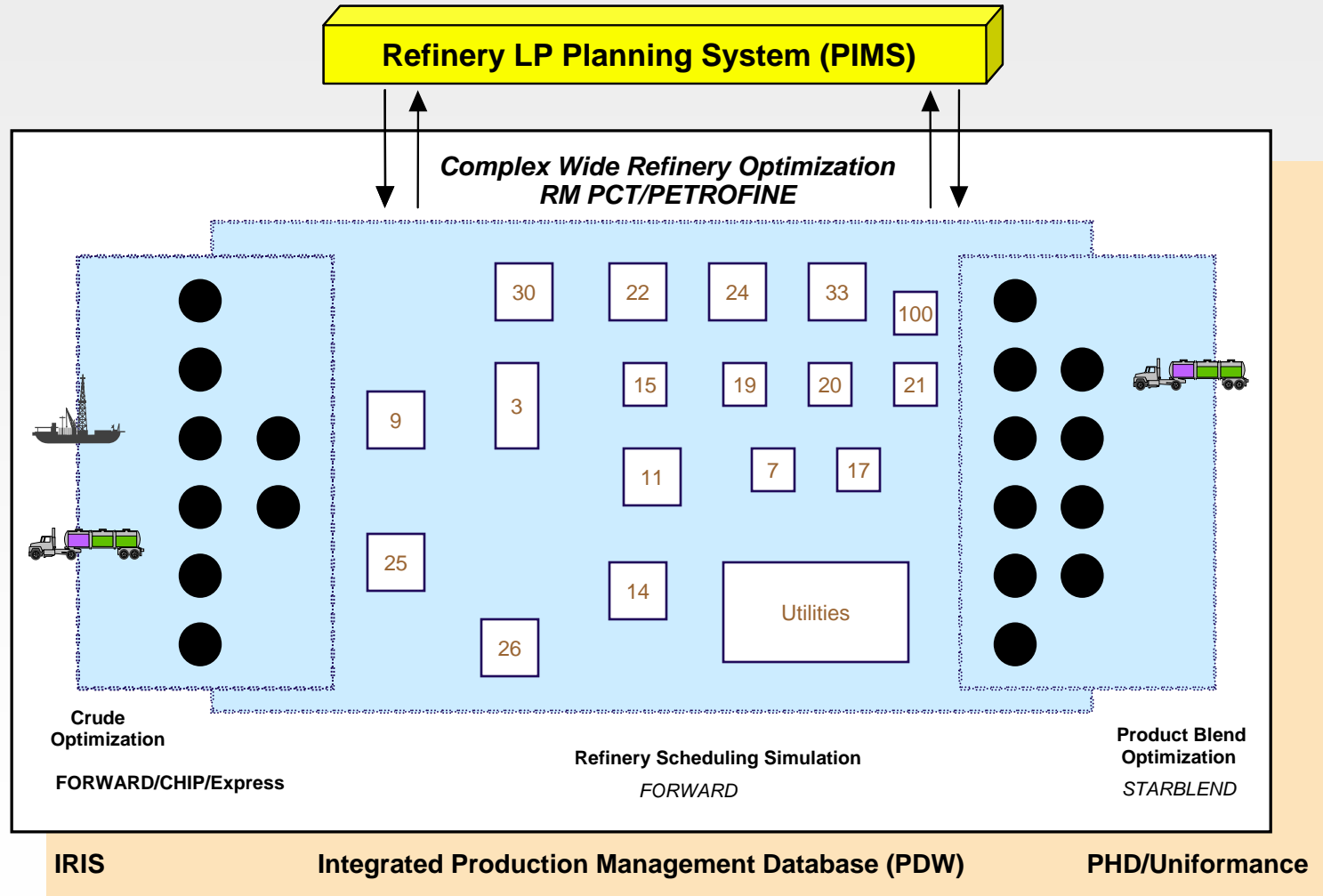



Vision & Investment To Date

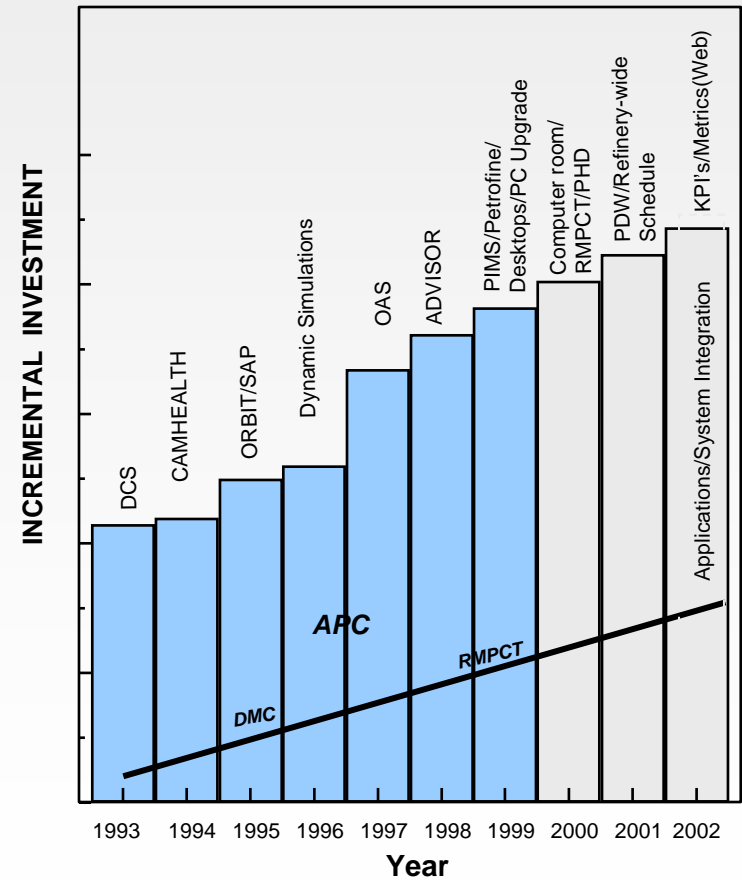
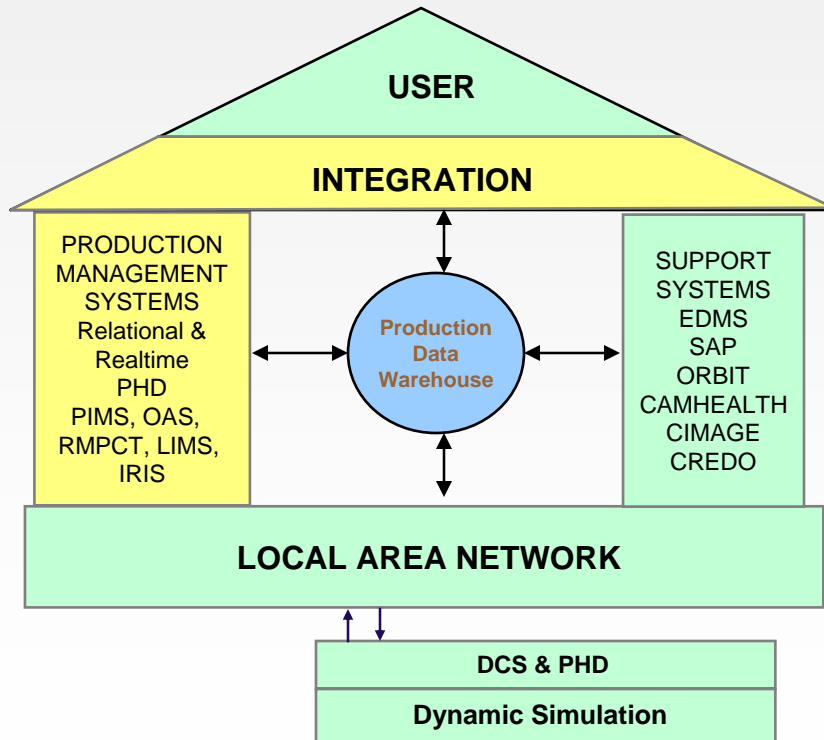



Texaco CITI Score

CITI Category	Quartile			
	Upper	2	3	Lower
Organizational and Business Process	√			
Business Incentives		√		
IT Practice and Architecture		√		
IT Applications		√		



Key Value Stream

- ◆ Optimize key value streams in the Pembroke Refinery within the business unit and across unit boundaries

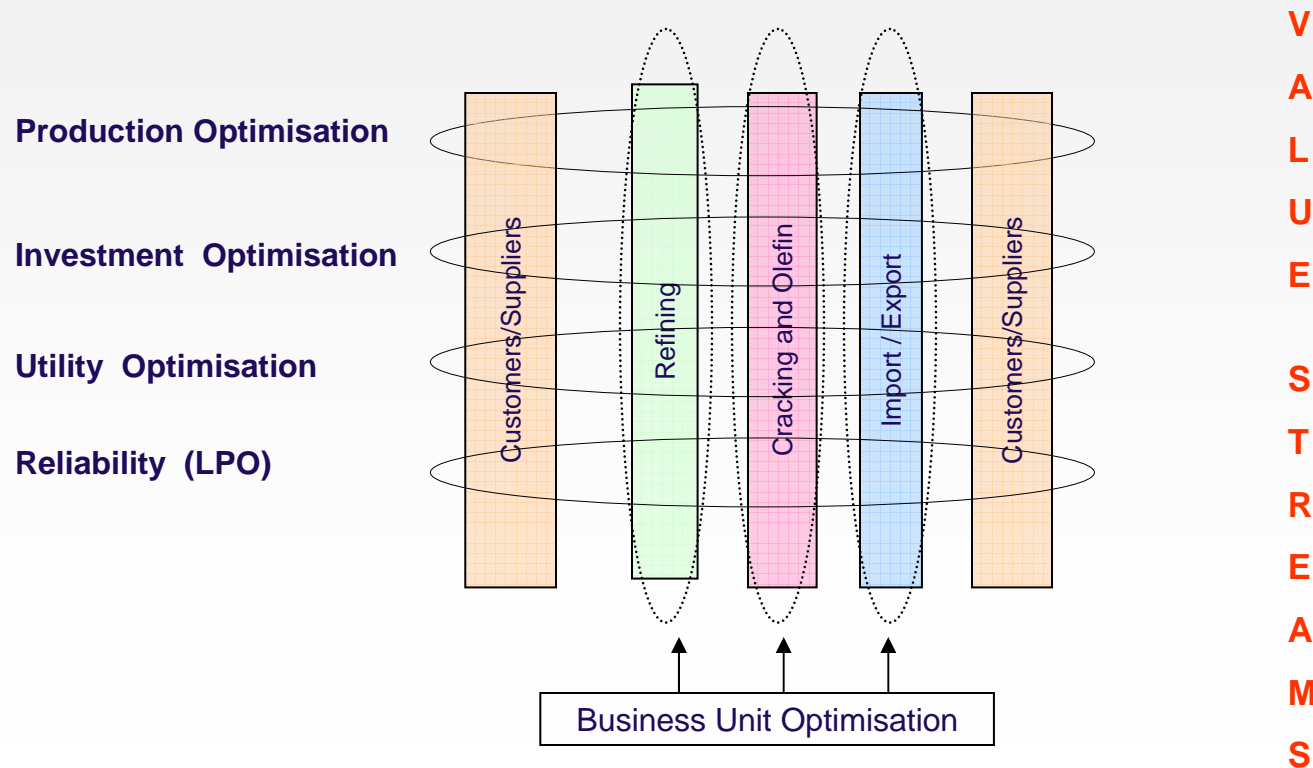



CITI Benchmarking Score

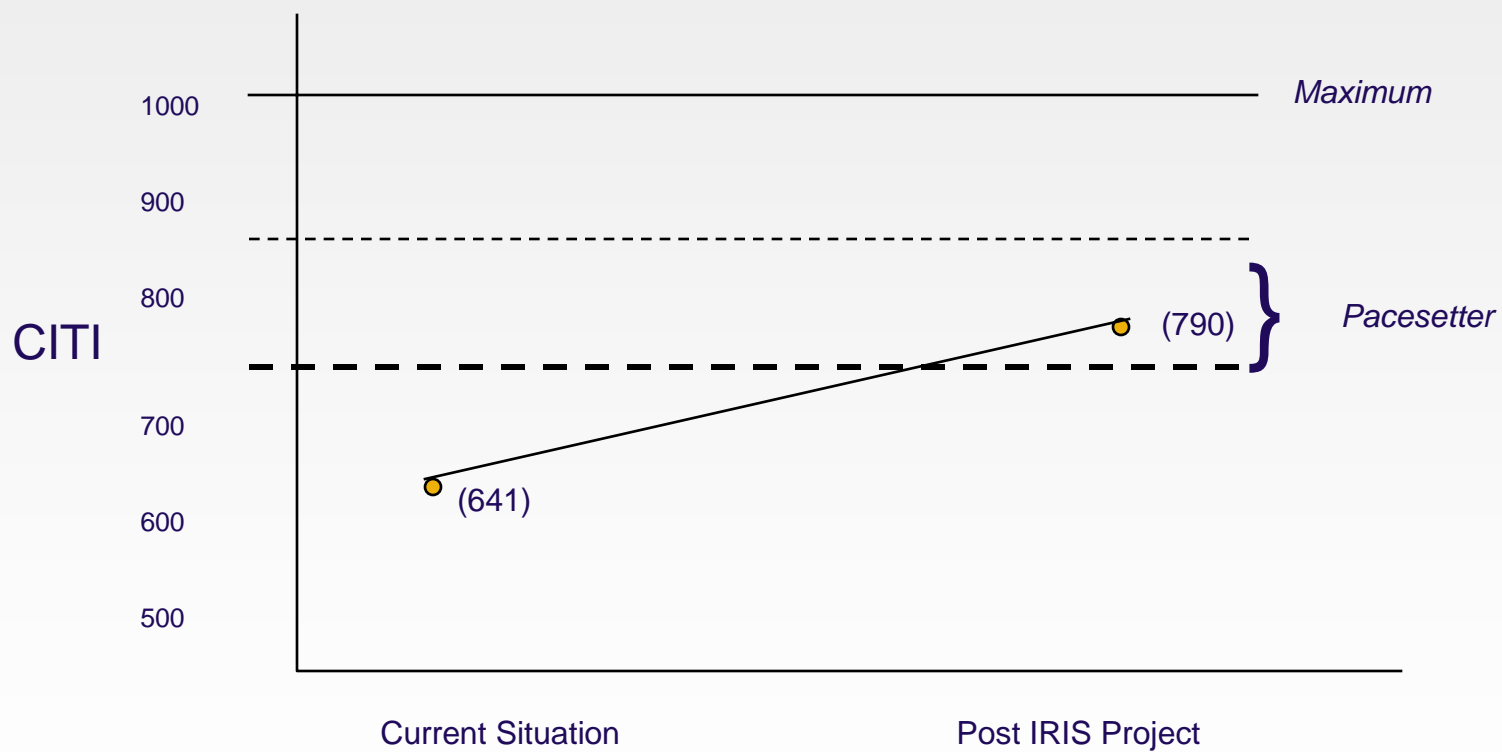



IRIS Concept and Scope

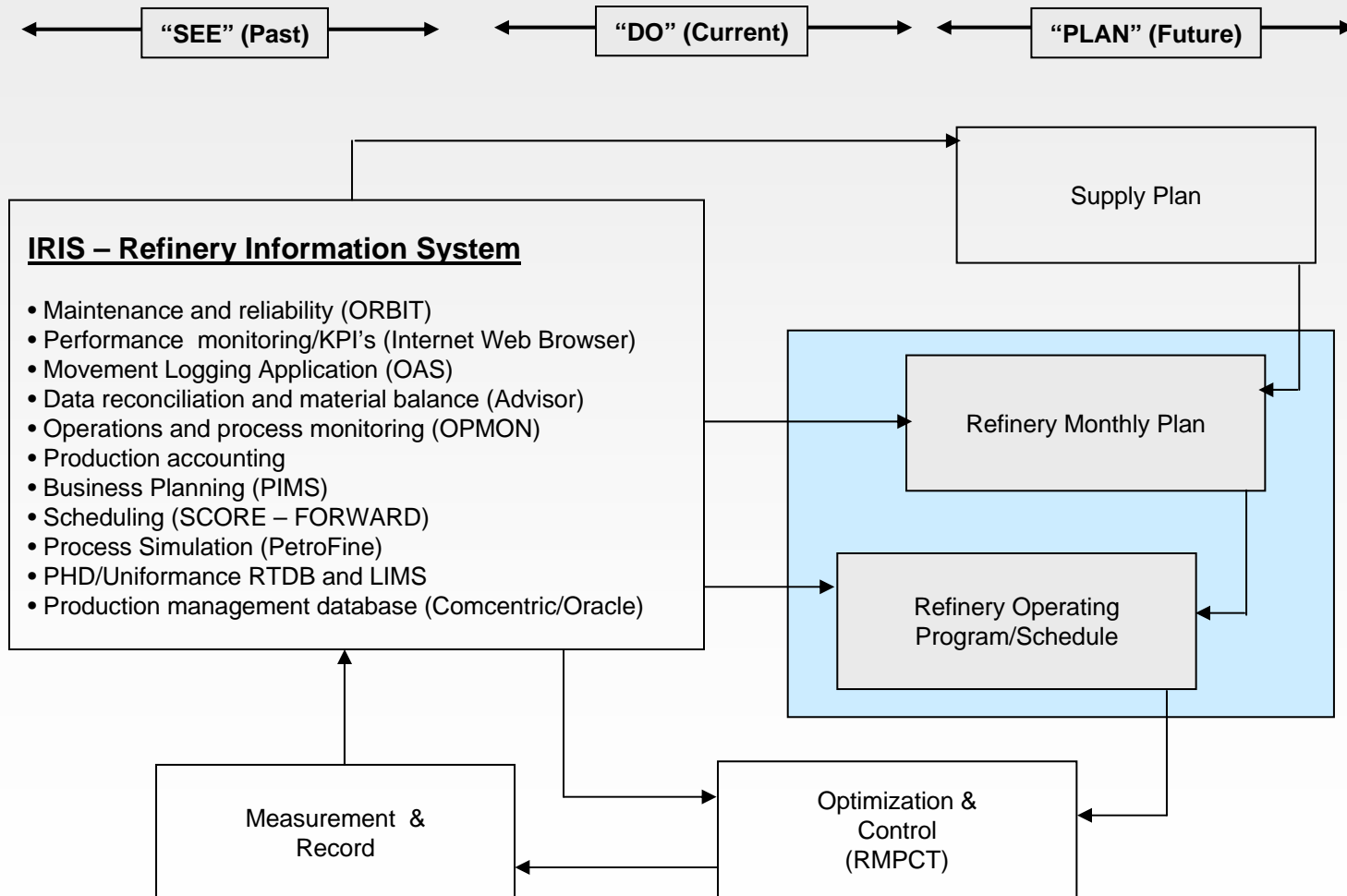



IRIS Business Improvements Strategy

- ◆ Refinery optimization in line with market economics, business drivers and key performance indicators
- ◆ Better understanding of individual unit and overall refinery actuals and capabilities
- ◆ Communicate and gain commitment to planned volumes and specifications
- ◆ On-line accurate performance data to support compliance with plan and deviation analysis
- ◆ Improve models updating and calibration for refinery LP
- ◆ Identify and capture more lost opportunities



IT Vertical Integration (Reference Architecture)

Business Information System (BIS/ERP)

Production Management System (IRIS)

Real Time System (RTDB)

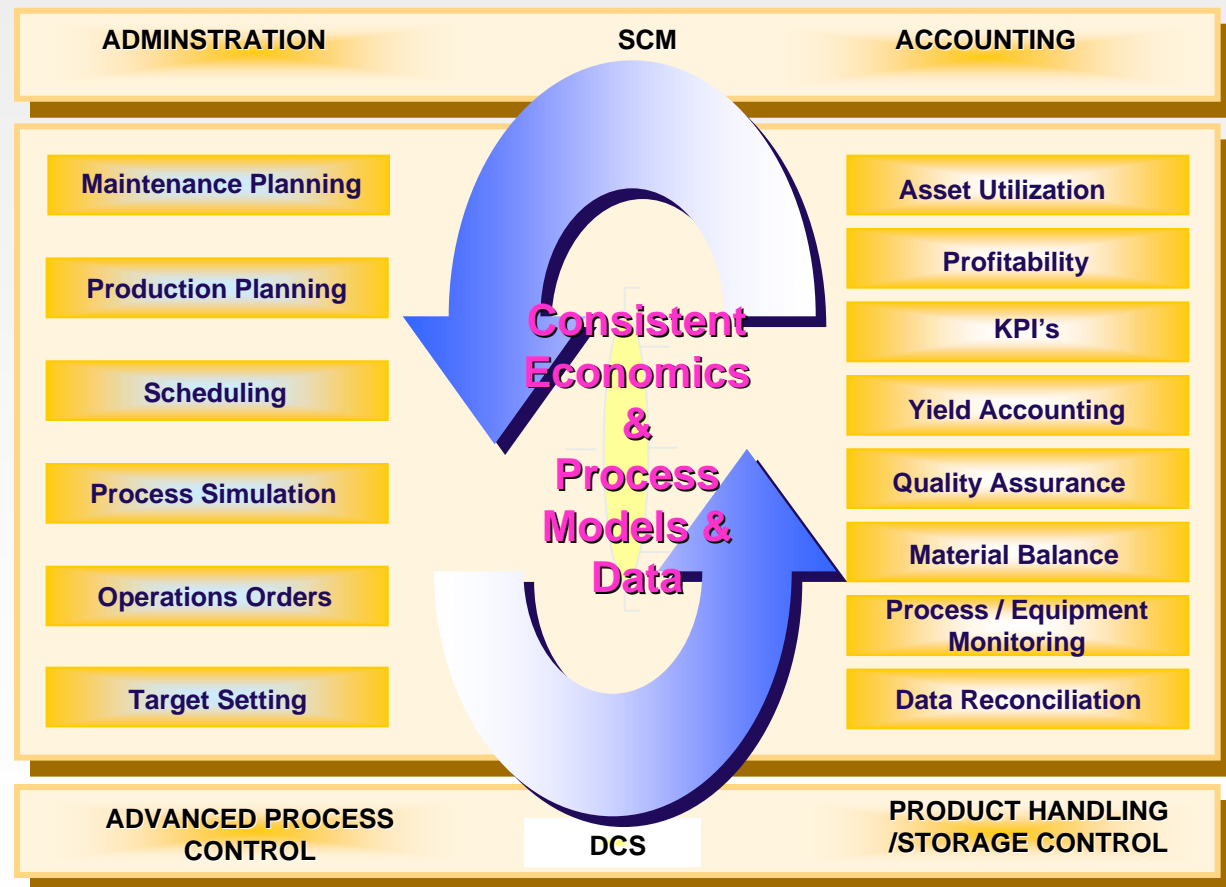



Logical Data Centric Architecture

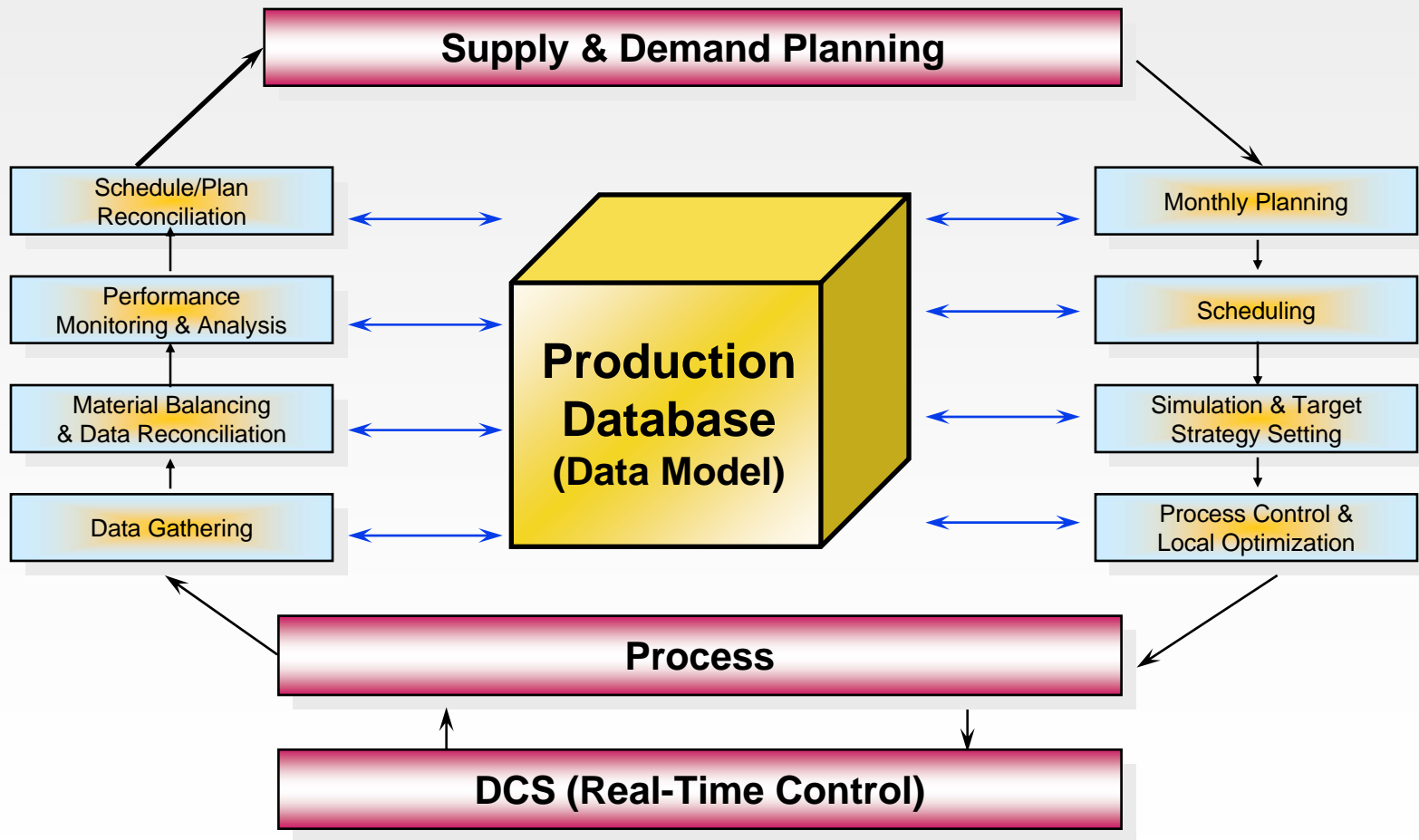



Applications & Systems Integration

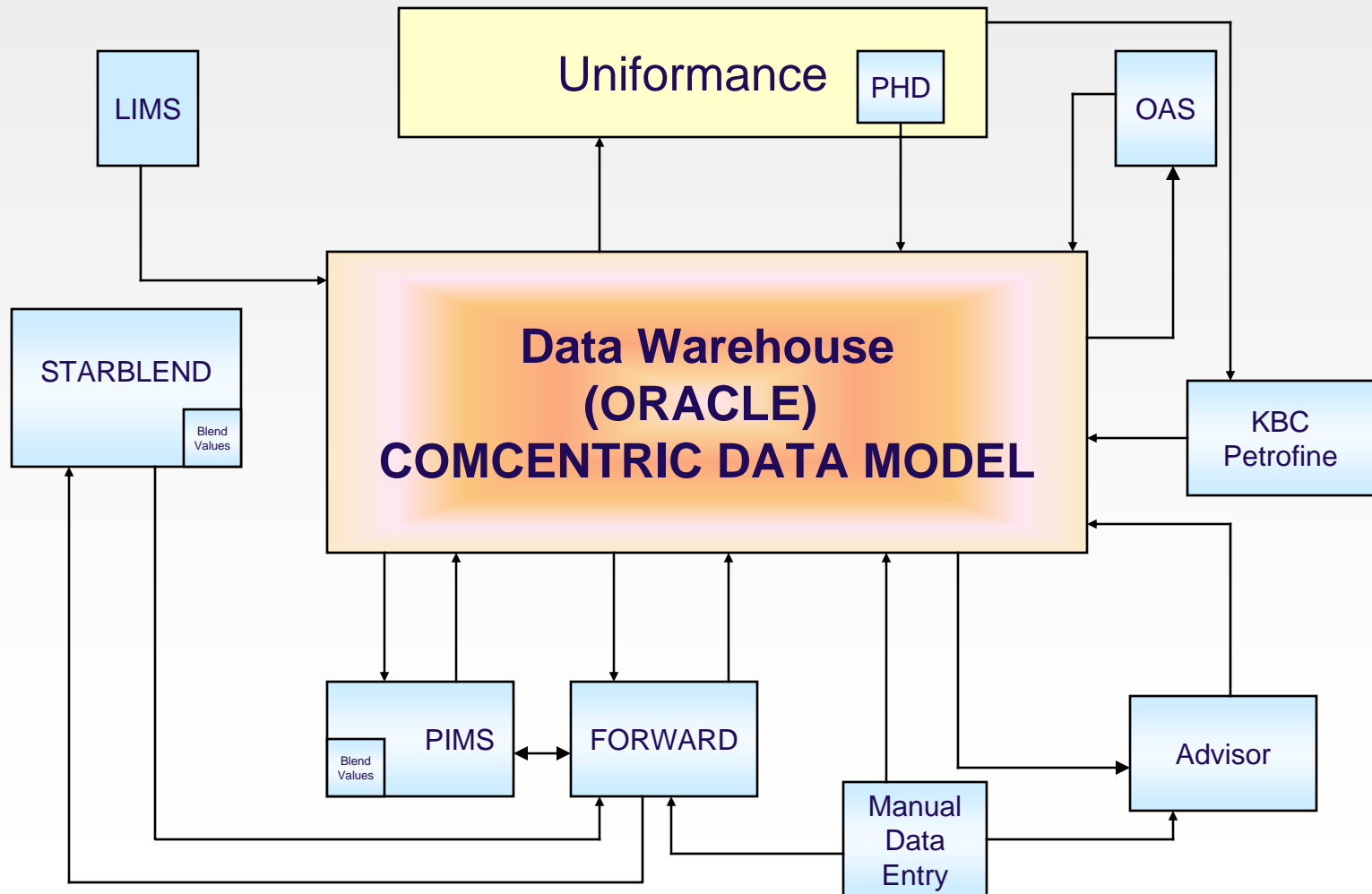



IRIS Benefits & Metrics

- ◆ Value out the plan
- ◆ Value out quality deviations
- ◆ Percentage of high value products
- ◆ Percentage of lower cost feedstock
- ◆ New business processes adopted



IRIS

